

PS-X4



Canadian, AEP, UK model
(Cartridge is not supplied with
this turntable system.)



E model

Canadian Model
E Model
AEP Model
UK Model

AUTOMATIC STEREO TURNTABLE SYSTEM

SPECIFICATIONS

GENERAL

Power Requirements: 110, 120, 220, 240 V ac~, adjustable,
50/60 Hz (E, AEP, UK model)
120 V ac~, 60 Hz (Canadian model)

Power Consumption: 12 W (E, AEP, UK model)
8 W (Canadian model)

Dimensions: Approx.
445 (w) x 150 (h) x 375 (d) mm
Approx.
17½ (w) x 5⅞ (h) x 14¾ (d) inches
including projecting parts and
controls

Weight: Approx. 10.9 kg, 24 lb, net
Approx. 12.7 kg, 28 lb, with shipping
carton (E, AEP, UK model)

Approx. 10.3 kg, 22 lb 12 oz, net
Approx. 12.1 kg, 26 lb 11 oz, with
shipping carton (Canadian model)

TURNTABLE

Platter: 31.7 cm, 12½ inches, aluminum-
alloy diecast

Drive System: Direct drive, crystal lock control
system

Speeds: 33⅓, 45 rpm
Starting characteristics comes to
nominal speed within a third
revolution (33⅓ rpm)

Wow and Flutter: ±0.045 % (DIN)
0.025 % (WRMS)

S/N Ratio: 73 dB (DIN-B)

Initial Drift: Within 0.0003 %

Load Characteristics: 0% at 150 g tracking force

Speed Deviation: Within 0.003 %

Automatic System: Arm return, reject

TONARM

Type: Statically balanced, universal

Arm Length: 300 mm, 17⅞ inches, overall
216.5 mm, 8½ inches, pivot-
to-stylus

Overhang: 16.5 mm, 2⅓ inches

Tracking Error: +3°, -1°

**Tracking-force
Adjustment Range:** 0 - 3 g

Shell Weight: 10.5 g

Cartridge Weight Range: 2.5 - 9.5 g
8 - 14.5 g with extra weight

- Continued on next page -

SAFETY-RELATED COMPONENT WARNING!!

COMPONENTS IDENTIFIED BY SHADING ON THE SCHEMATIC DIAGRAMS AND IN THE PARTS LIST ARE CRITICAL TO SAFE OPERATION. REPLACE THESE COMPONENTS WITH SONY PARTS WHOSE PART NUMBERS APPEAR AS SHOWN IN THIS MANUAL OR IN SUPPLEMENTS PUBLISHED BY SONY.

SONY®

SERVICE MANUAL

PS-X4

MODEL IDENTIFICATIONS

— Specification Label —

Canadian model

SONY [®]	STEREO TURNTABLE SYSTEM
	PS-X4
	AC 120V 60 Hz 8W
	SERIAL NO. _____ MADE IN JAPAN

E, AEP, UK model

SONY [®]	STEREO TURNTABLE SYSTEM
	PS-X4
	~110, 120, 220, 240V 50/60 Hz 12W
	SERIAL NO. _____ MADE IN JAPAN

3.4.1.1

SECTION 1 OUTLINE

1-1. BLOCK DIAGRAM

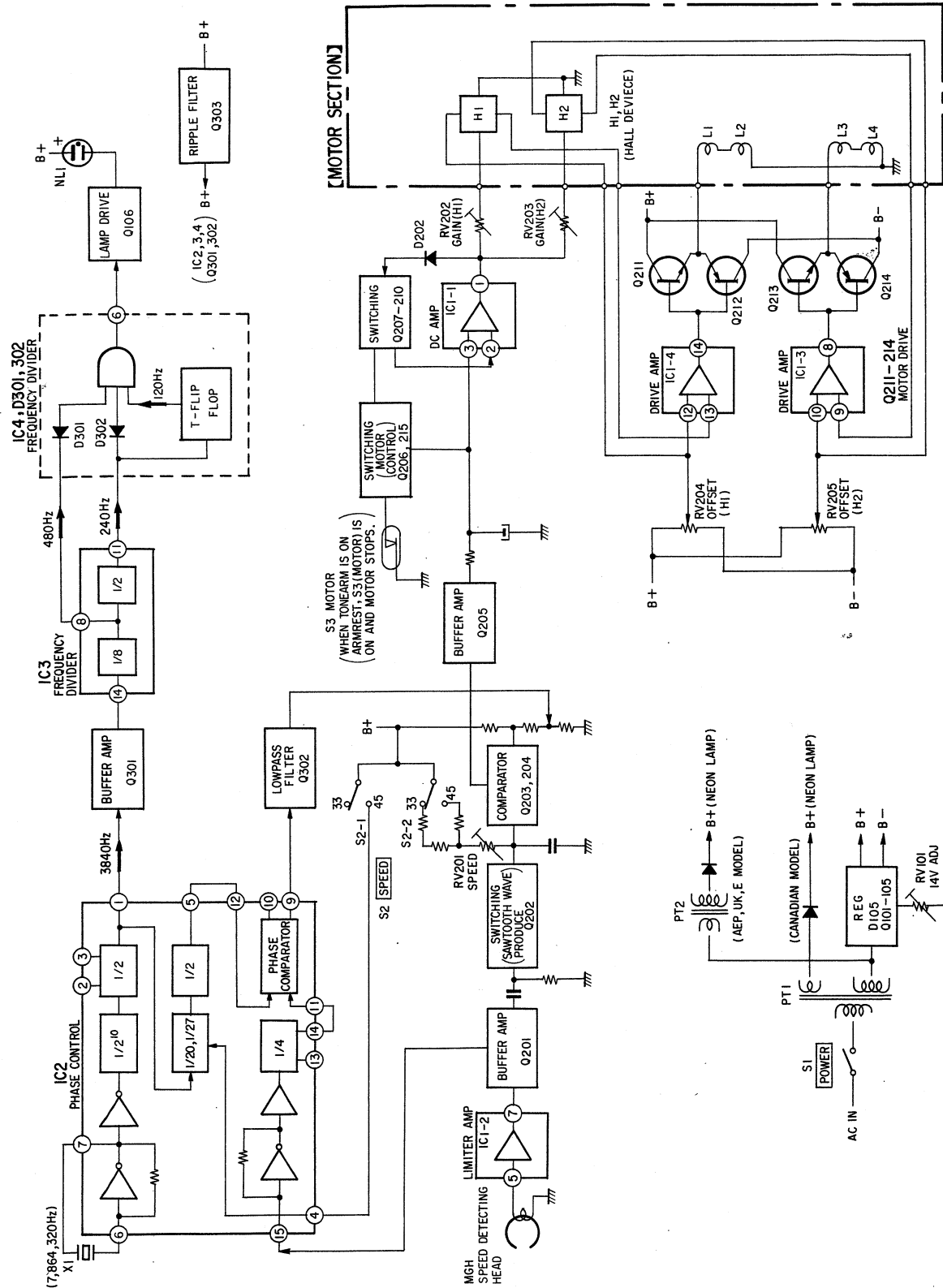

1-2. TECHNICAL DESCRIPTION

This model uses the BSL (brushless and slotless) motor and the crystal-locked magnedisc servo control system to maintain the turntable rotation at an accurate and a stable speed.

Automatic arm return at end of record and reject function during play assure easy operation.

- The reject function can be performed by pushing the REJECT button even with the dust cover closed.
- Moving the tonearm toward the turntable by hand, the motor automatically starts to rotate by using a reed switch and a magnet. After play, when the tonearm return to the arm rest, the motor stops rotating. In these switching, the tonearm does not contact any lever.

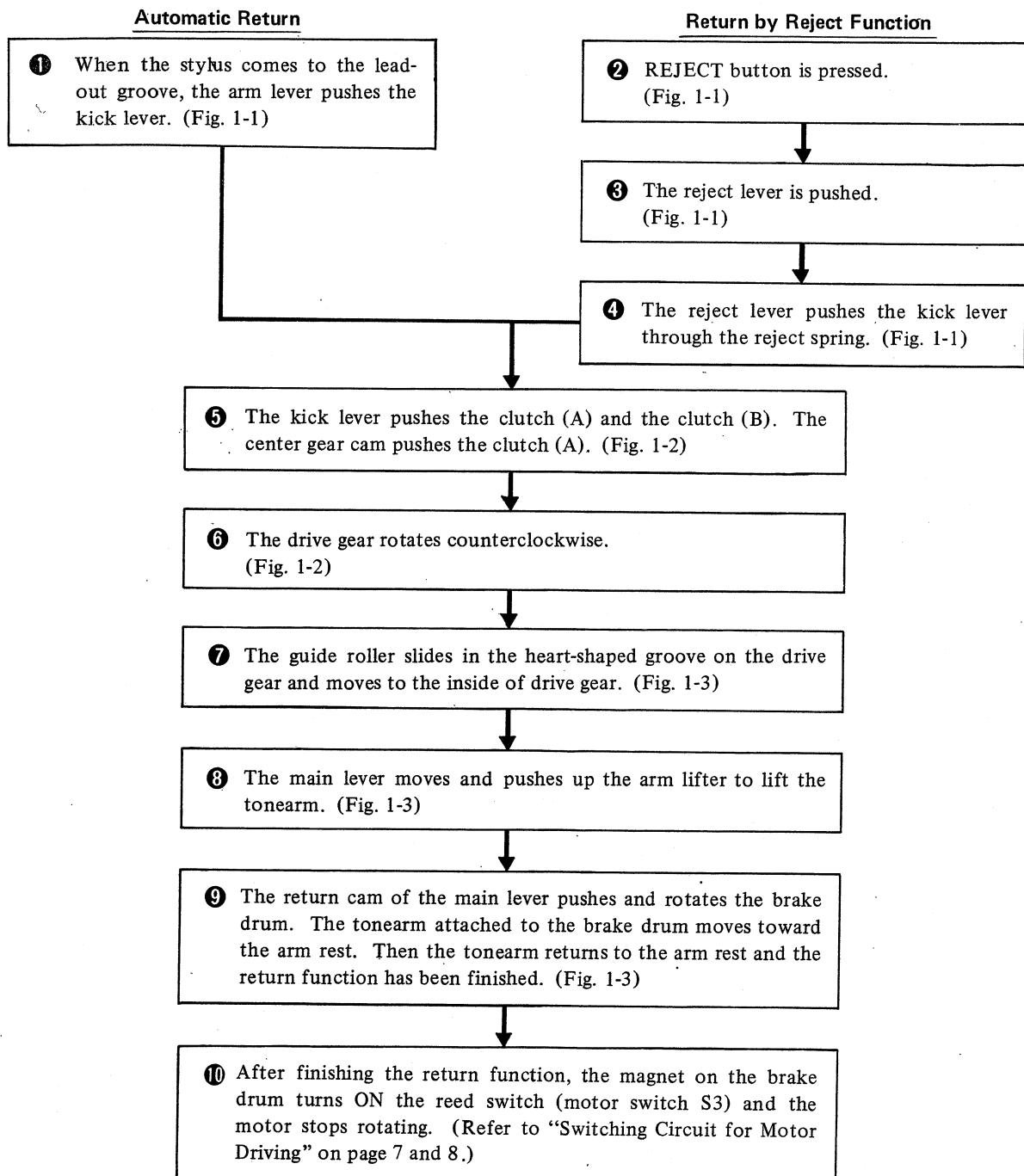
Tonearm Return Mechanism

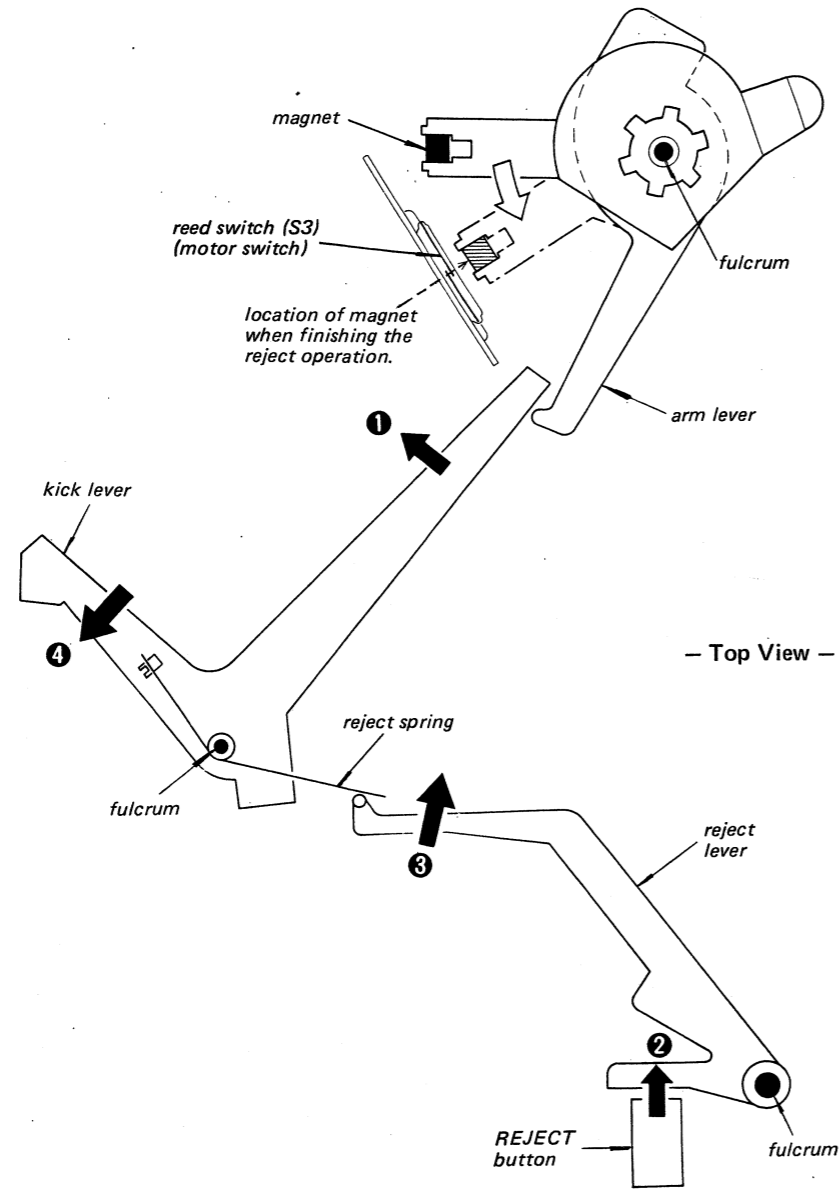

Fig. 1-1

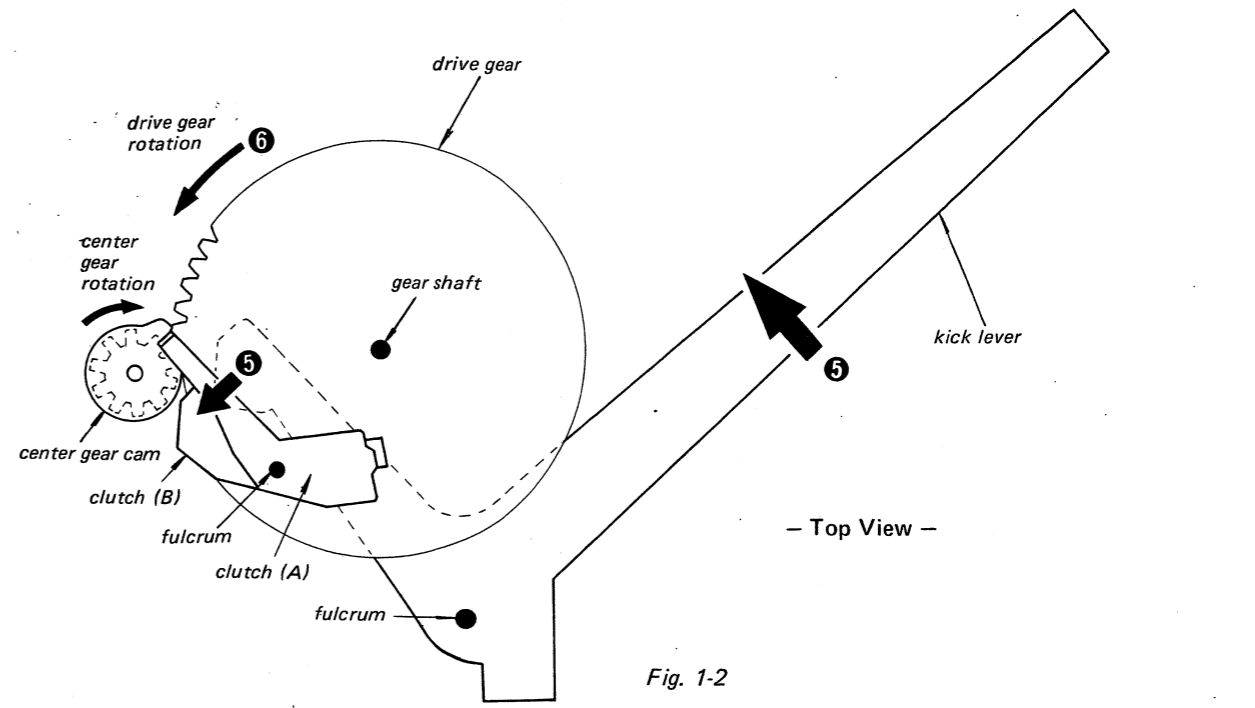

Fig. 1-2

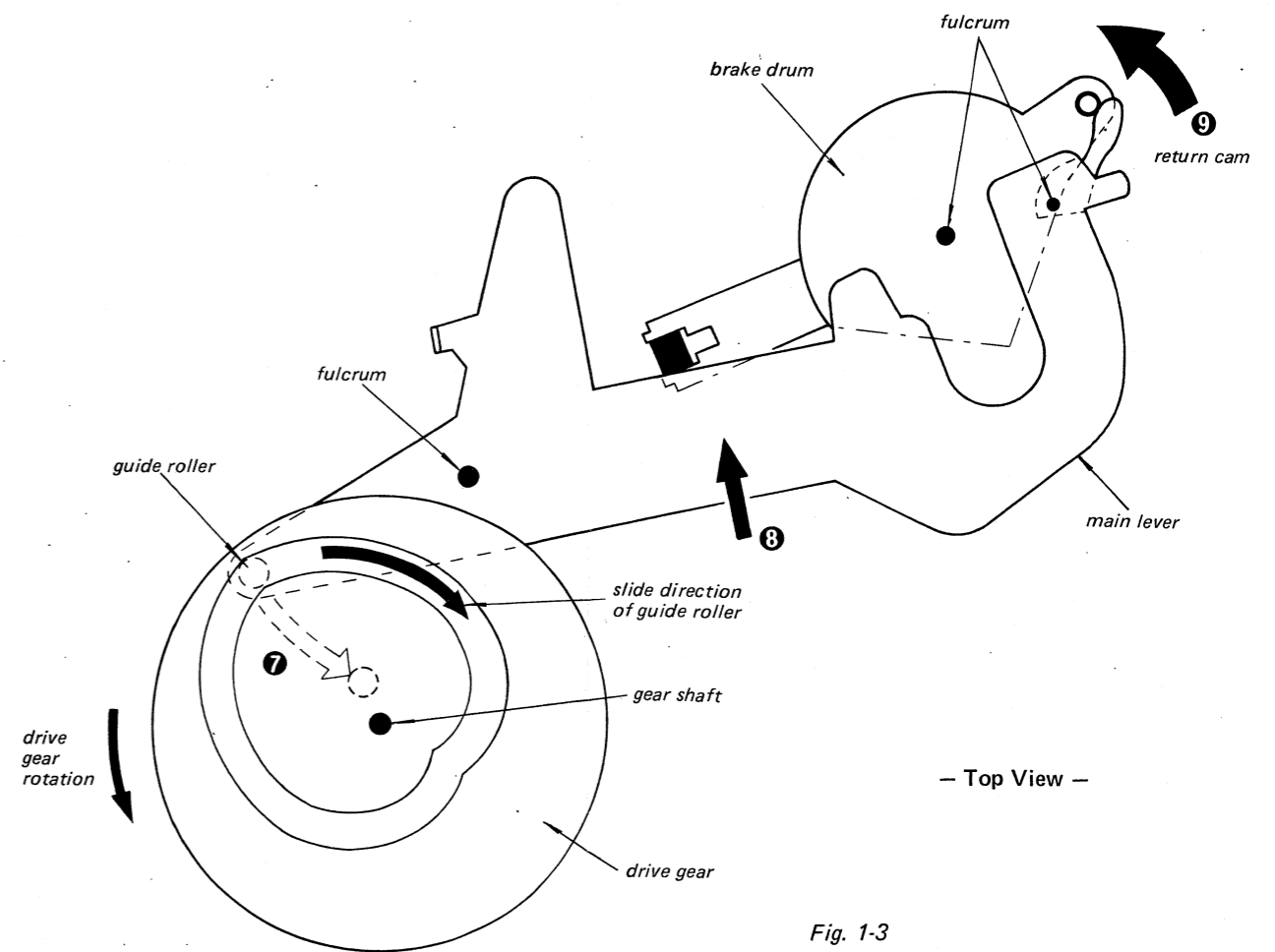

Fig. 1-3

Switching Circuit for Motor Driving

The magnet on the brake drum, the reed switch (motor switch S3) and the motor control circuit Q215 and Q206 operate as follows:

Moving the tonearm toward the turntable by hand, the motor automatically starts to rotate. (Refer to Fig. 1-4.)

1. The magnet on the brake drum moves away from the motor switch S3 to turn it OFF.
2. Q215 turns ON and Q206 turns OFF. The motor-drive signal is applied to terminal 3 of IC1-1 and the output signal from terminal 1 of IC1-1 drives the motor. Q207 also turns ON and the positive voltage is applied to terminal 2 of IC1-1 to quickly

stabilize the motor rotation when the speed is changed from 45 rpm to 33-1/3 rpm.

After playing record or when pushing REJECT button, the tonearm automatically returns to the arm rest and the motor stops rotating. (Refer to Fig. 1-5.)

1. The magnet on the brake drum approaches the motor switch S3 to turn it ON.
2. Q215 turns OFF and Q206 turns ON. The motor-drive signal, therefore, is muted. Q207 also turns OFF and no signal is applied to IC1-1.
3. No output from IC1-1 is applied to the motor and the motor stops rotating.

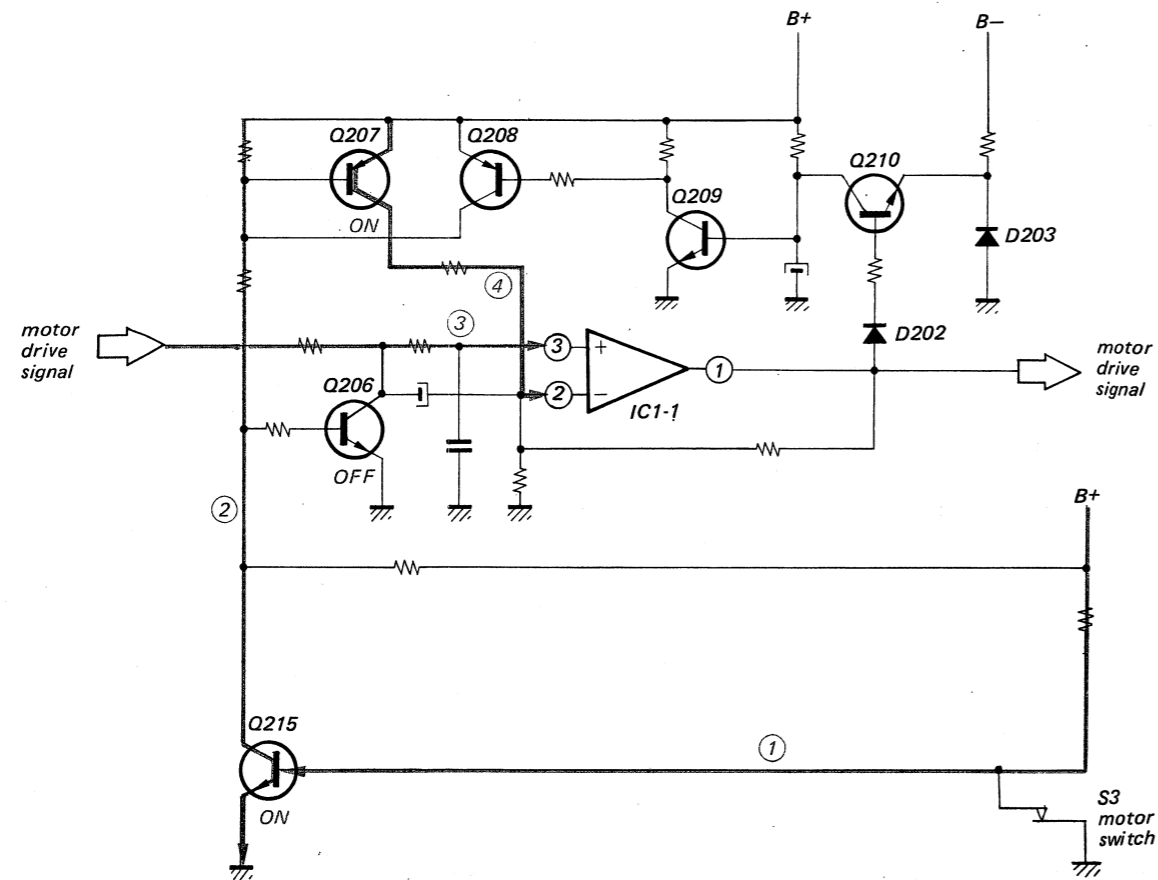

Fig. 1-4

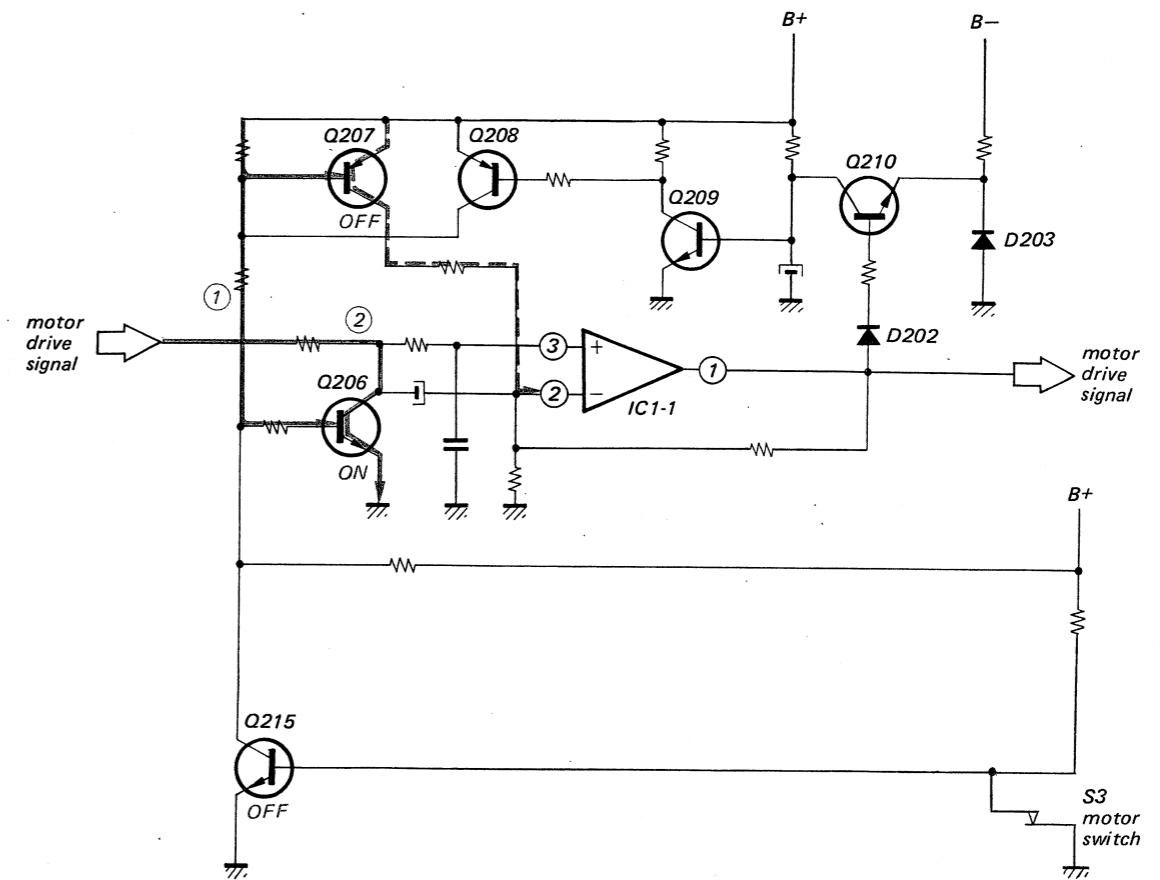
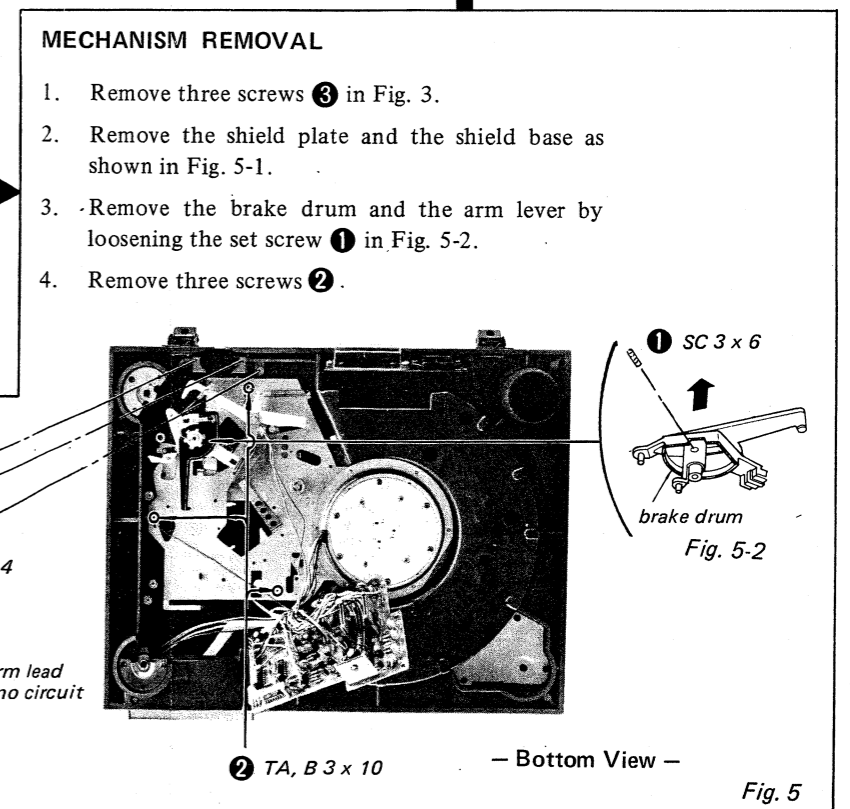
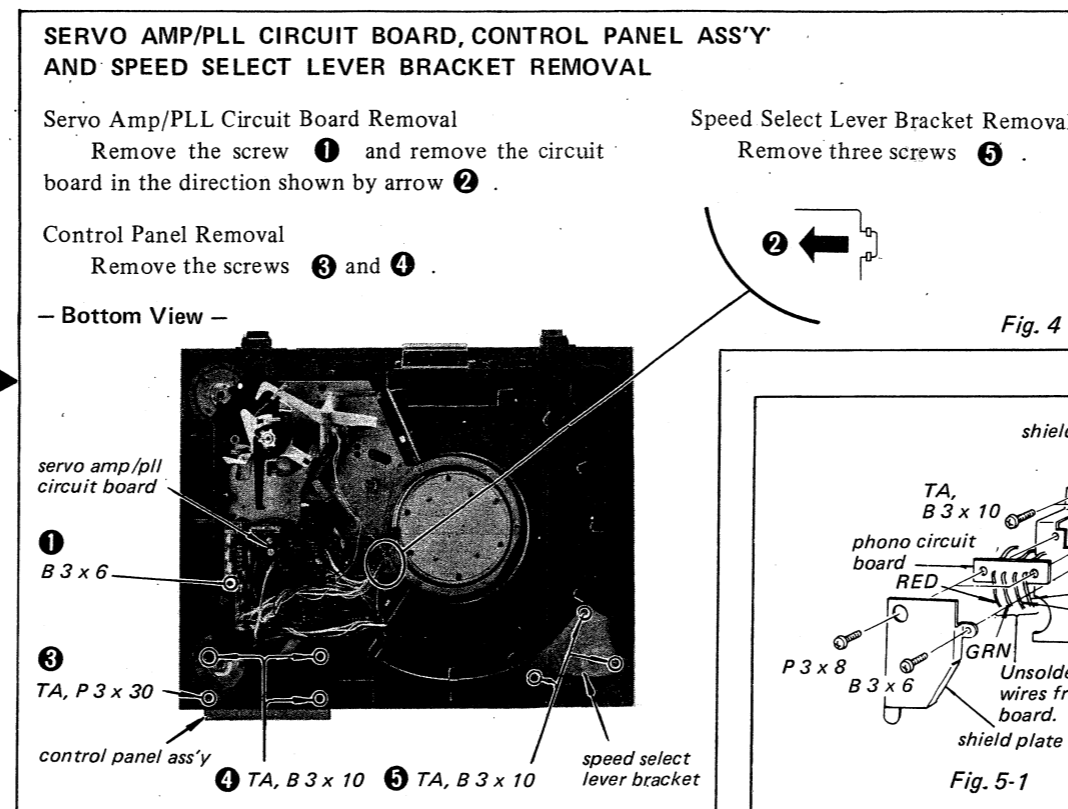
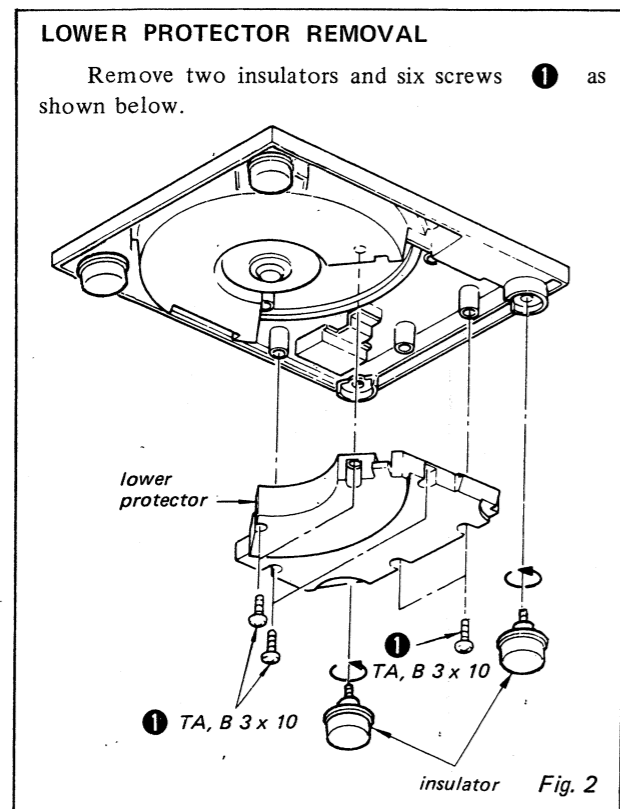
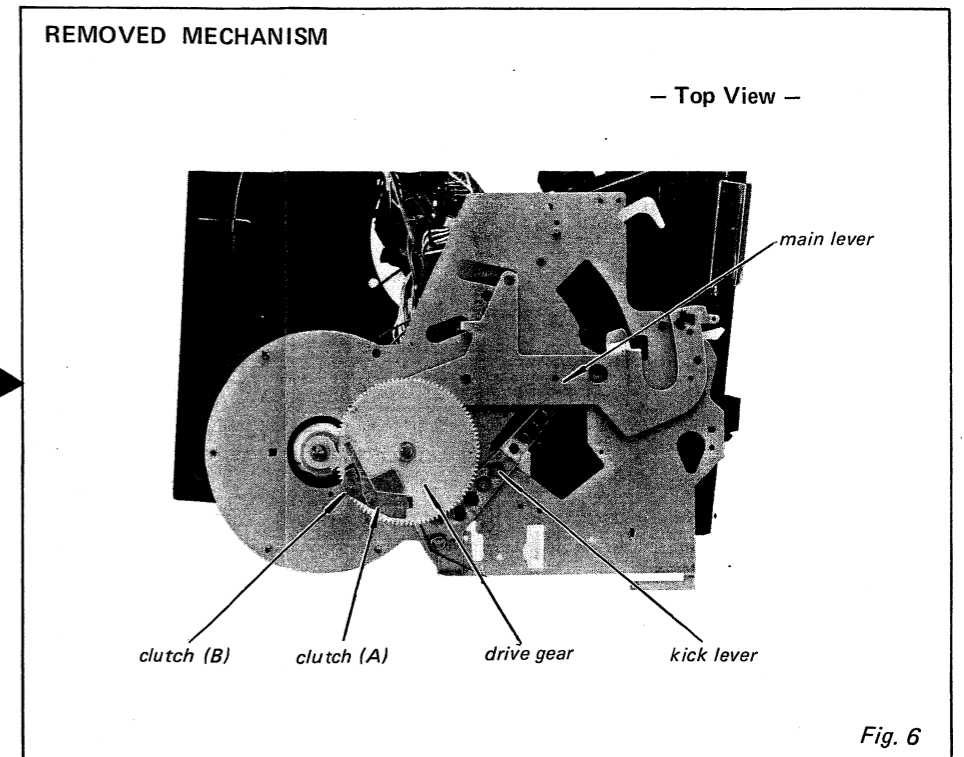
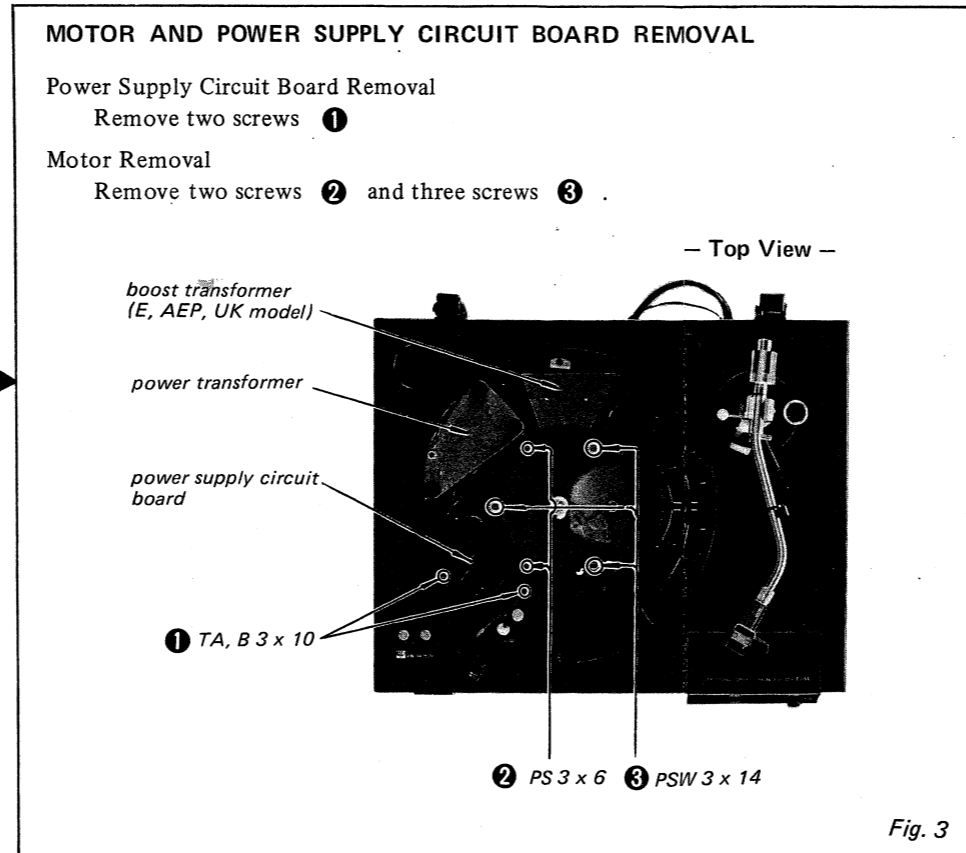
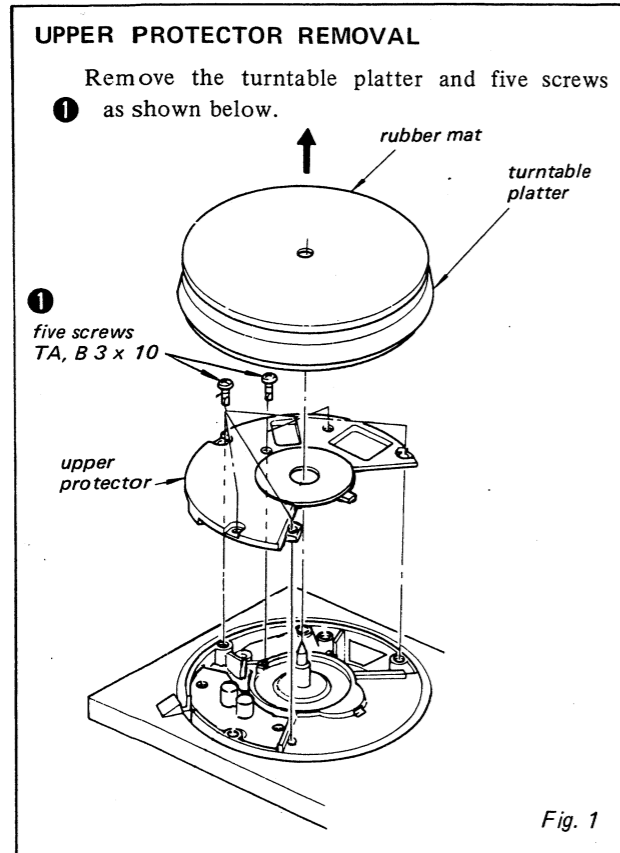

Fig. 1-5

SECTION 2
DISASSEMBLY



SECTION 3
ADJUSTMENTS

ARM LIFTER SHAFT REMOVAL

• Remove in the numerical order.

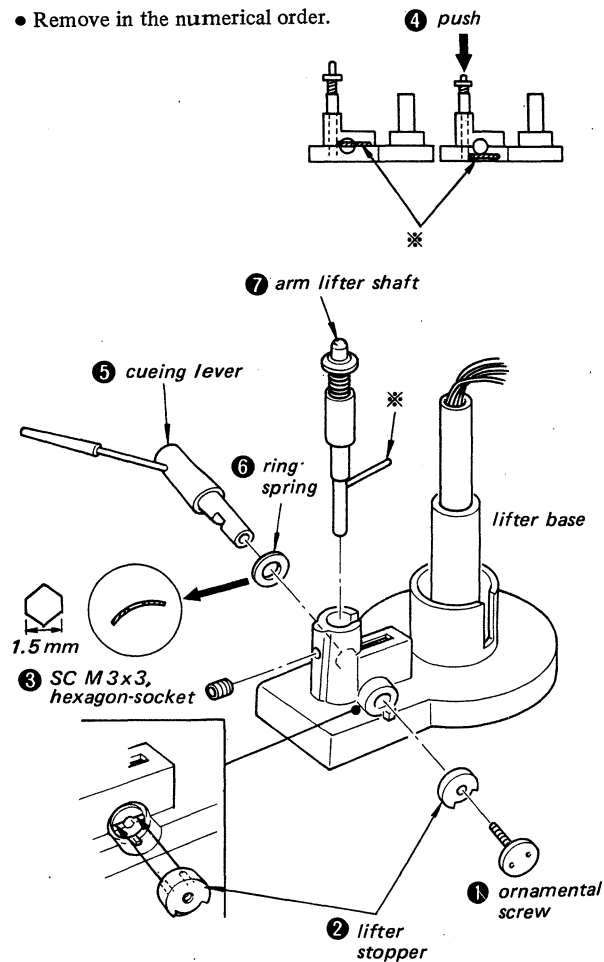

Note:

- When installing the cueing lever, take care to the direction of the spring ⑥.
- After installing the cueing lever, make sure that the arm lifter shaft is smoothly moved up and down by the cueing lever.

LATERAL BALANCER WEIGHT INSTALLATION

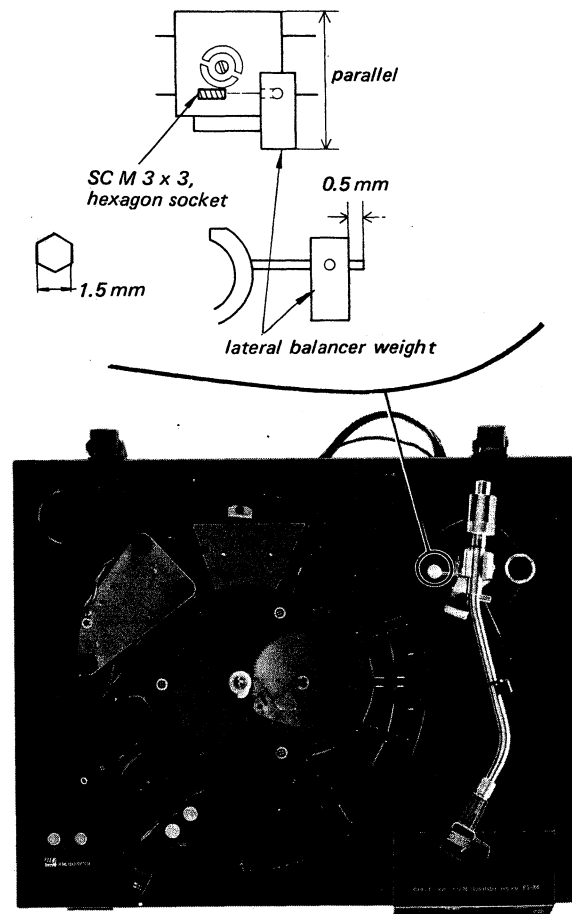

LIFTER BASE INSTALLATION

Install the lifter base so that the clearance between the tone base and lifter base is 3.5 mm.

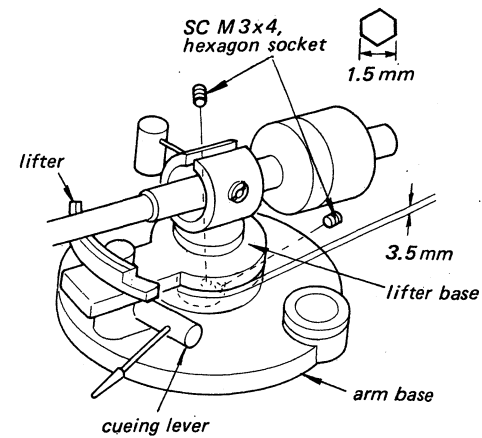

3-1. MECHANICAL ADJUSTMENTS

1. Brake Drum Position Adjustment

Tonearm: on the arm rest
POWER switch: OFF

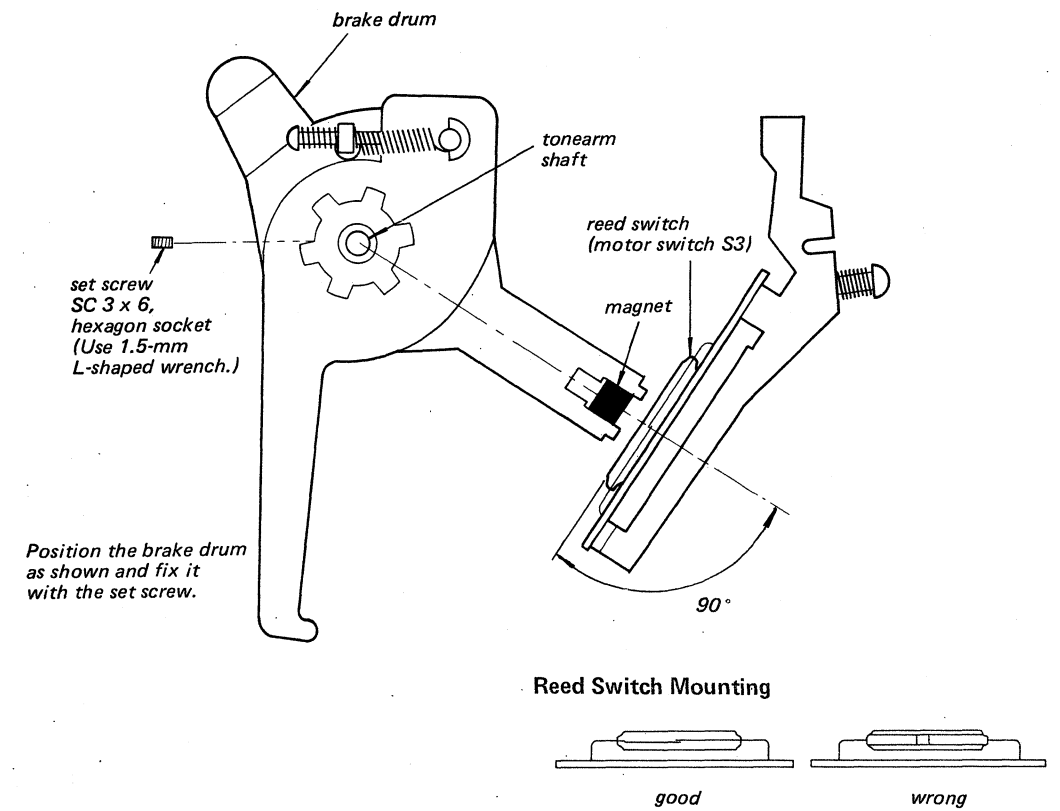

Arm Lifter Height Adjustment

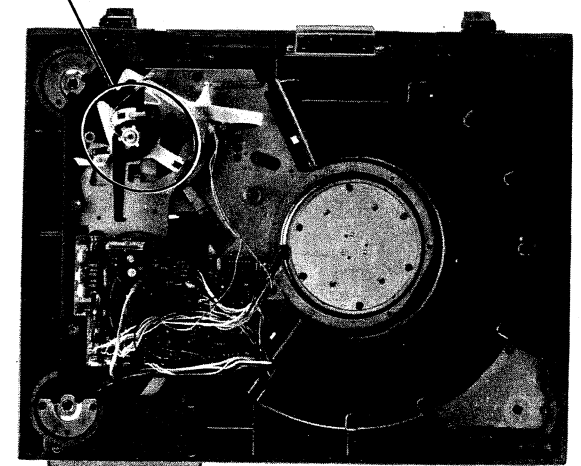
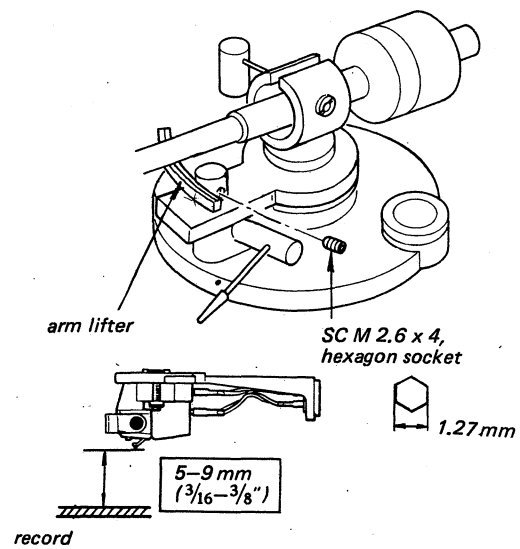

2. Reed Switch Position Adjustment

Tonearm: on the arm rest
POWER switch: OFF

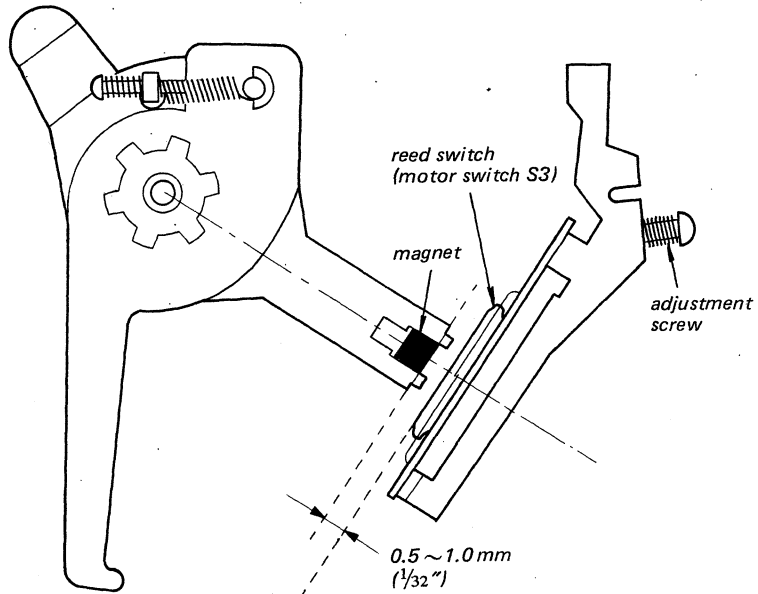

After the reed switch position adjustment, push POWER switch ON and confirm the following functions:

- a). Carefully move the tonearm toward the turntable by hand and confirm that the turntable starts to rotate before the inside of head shell comes at 5 mm (3/16") from the outer surface of turntable.
- b). Carefully return the tonearm toward the arm rest by hand and confirm that the motor stops rotating (The stroboscope pattern starts to flow.) before the tonearm pipe center comes at the inner edge of arm rest.

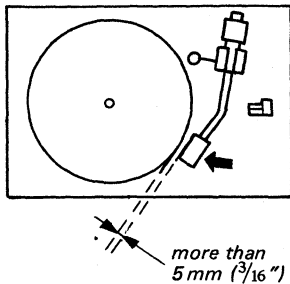

Fig. A Motor starts to rotate.

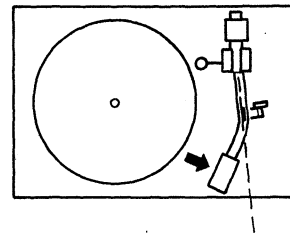
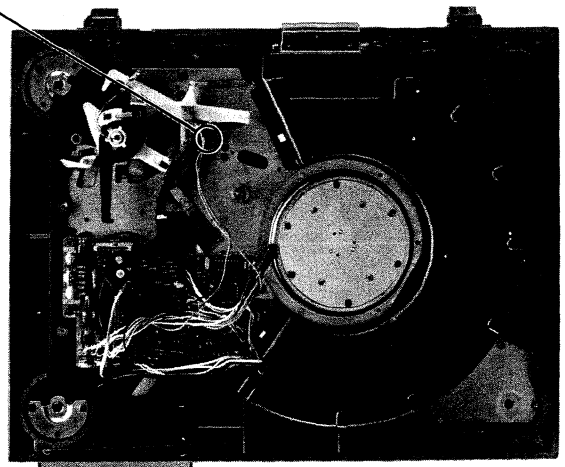

Fig. B Motor stops rotating.



3. Automatic Return Position Adjustment

POWER switch: OFF

1. Remove the rubber mat and the turntable.
2. Put the tonearm on the arm rest.
3. Turn the center shaft clockwise by hand and turn the drive gear one turn by engaging the center gear with the drive gear. The place the drive gear in the disengaging position.
4. Push the clutch (B) in the direction shown by the arrow and place the clutch (A) and clutch (B) as shown below:

5. Put the return adjustment scale (Part No. 9-911-814-01) on the center shaft.
6. Move the tonearm toward the center shaft by hand so that the clutch (A) is positioned as shown below and confirm that the stylus is located on the hatched area of the return adjustment scale.

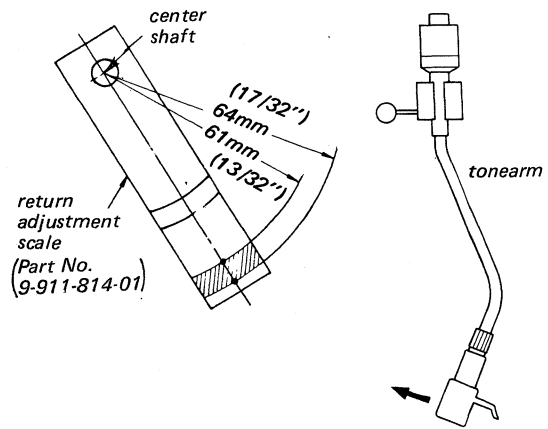
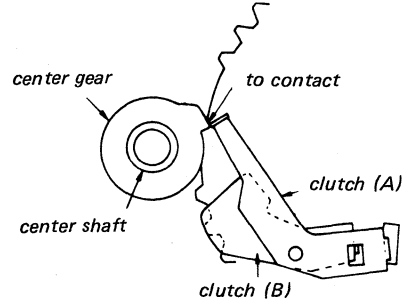
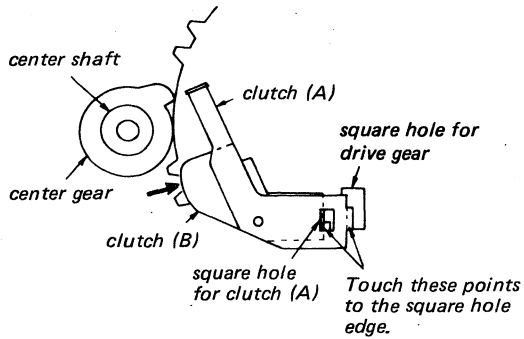

If necessary, adjust the adjustment screw.

Stylus Position	Adjustment Screw
outside of hatched area	clockwise
inside of hatched area	counterclockwise
on hatched area	correct

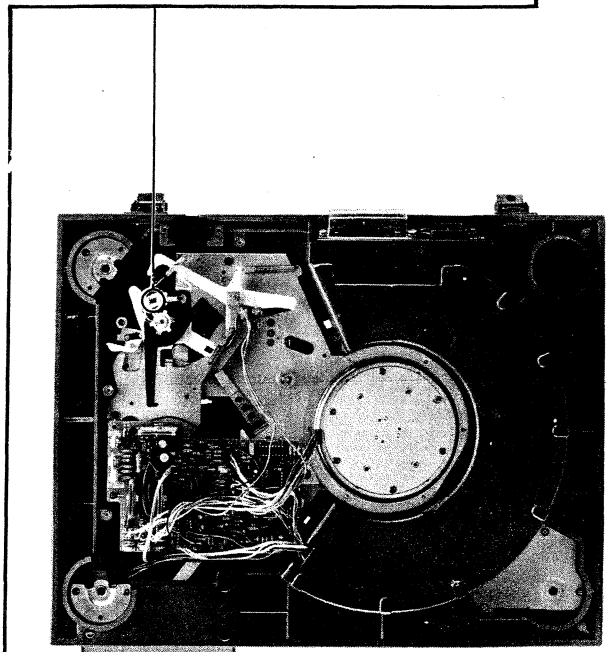
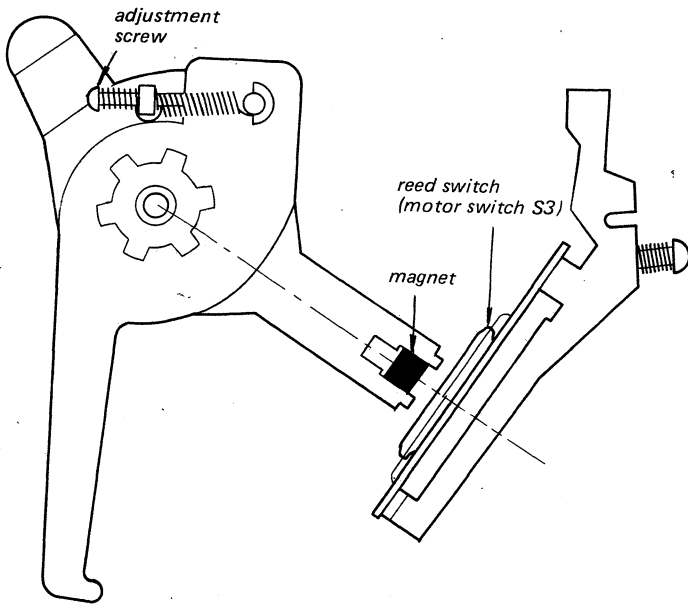

3-2. ELECTRICAL ADJUSTMENTS

1. B+ (14 V) Adjustment

Adjust RV101 for 14V reading on VOM.

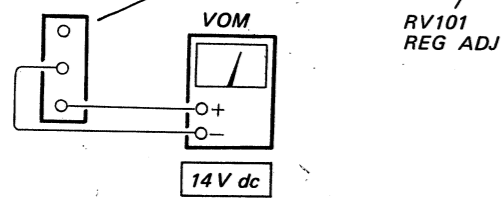
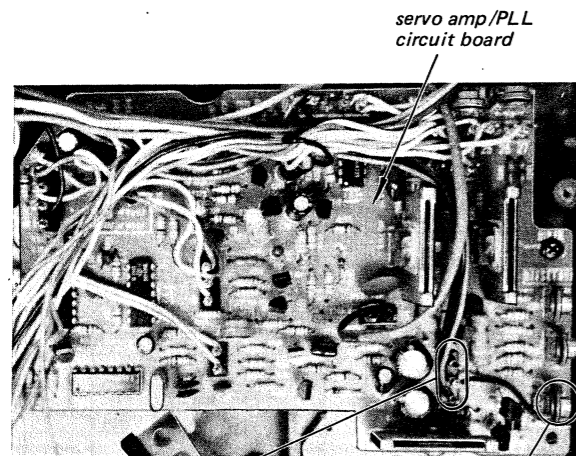

Note: Maladjustment results in abnormal wow-flutter characteristics.

Adjustment Location:

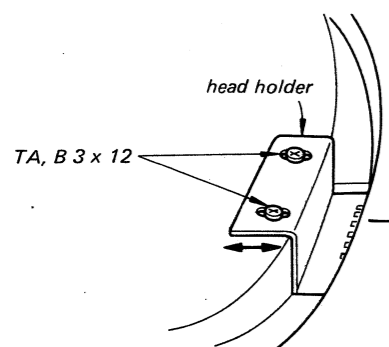

Note: The clearance between the magnet coated rim and the speed detecting head is more than 0.3 mm.

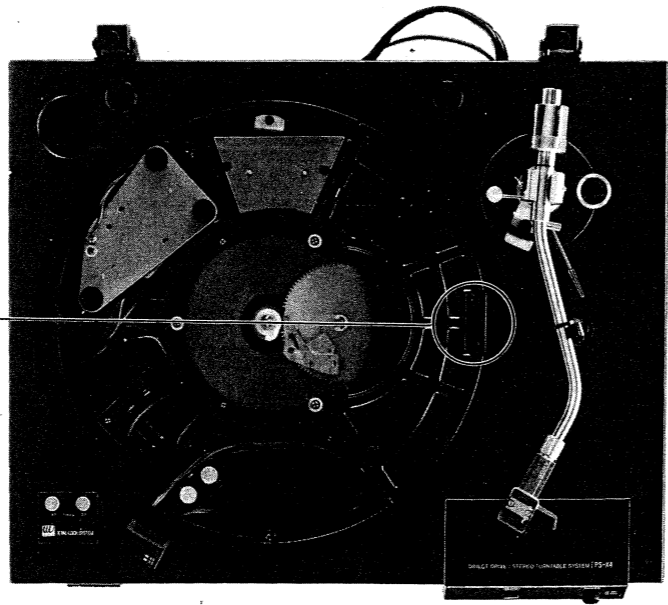

2. Speed Detecting Head Output Level Adjustment

Before this adjustment, set the speed detecting head on the head holder as shown below.

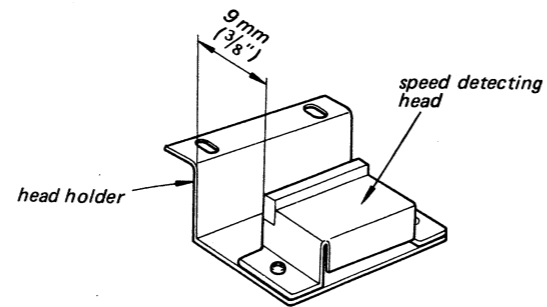

1. Adjust the position of the head bracket so that the VTVM reading is more than 30 mV at 33 1/3 rpm.
2. Make sure that the head does not touch the turntable and tighten the screws securely.

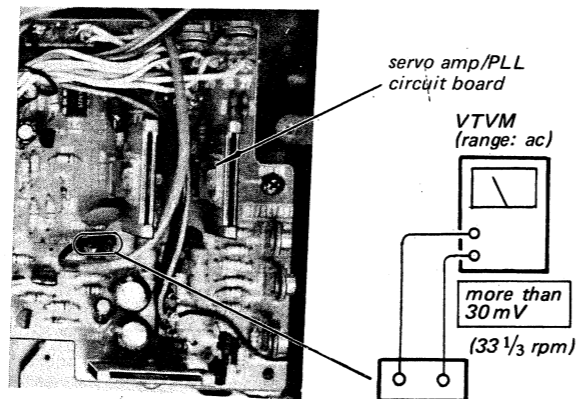

3. Turntable Speed Adjustment (33 1/3 or 45 rpm)

1. Disconnect the jumper wire and adjust RV201 so that the stroboscope pattern appears stationary.
2. Connect the jumper wire and make sure that the stroboscope pattern appears stationary after changing the turntable speed by hand.

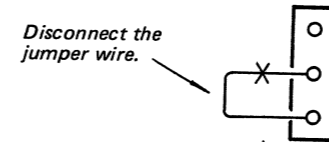

RV201
SPEED ADJ

4. Hall Device Gain Adjustment (33 1/3 rpm)

1. Disconnect the jumper wire and connect the regulated power supply as shown below.
- 2.
- 3.

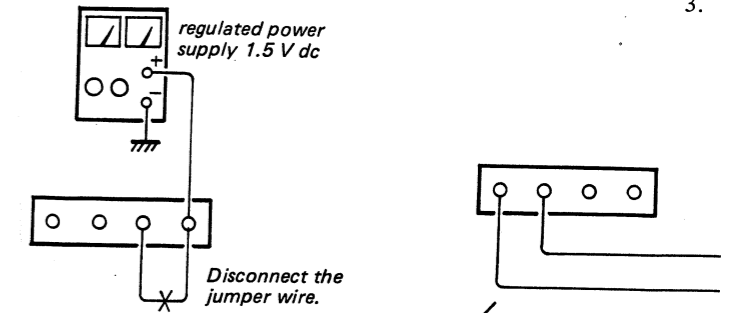

RV202
(H1)

RV
(H2)
GAIN
ADJ

control panel side

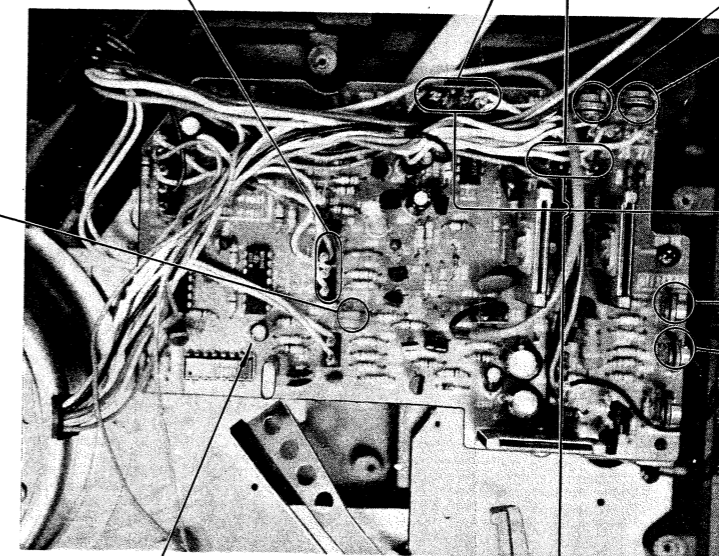

servo amp/PLL control circuit board

RV204

RV205 (I
OFFSET

- connect the
slow.
2. Connect VTVM to H1 and adjust RV202 for 1.9 V ac reading on VTVM.
 3. Connect VTVM to H2 and adjust RV203 for 1.9V ac reading on VTVM.

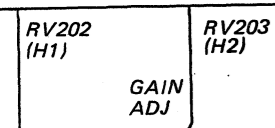
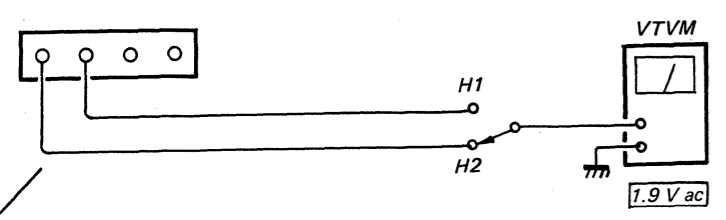

Adjustment Locations

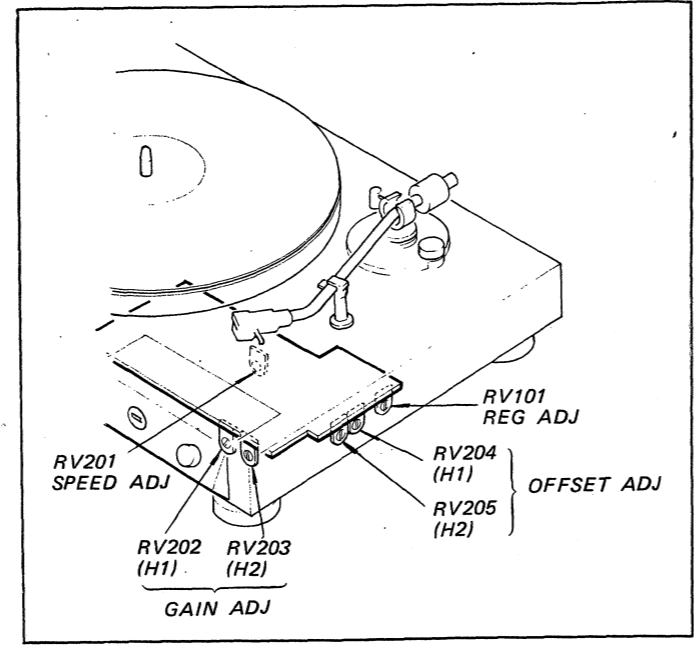

5. Motor Amp Offset Adjustment (33 1/3 rpm)

1. Disconnect the jumper wire and connect the regulated power supply as shown below.

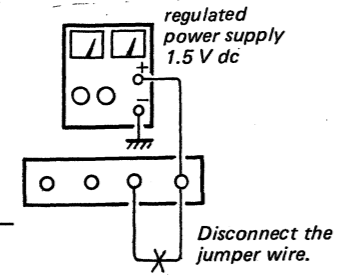

2. Connect VTVM or oscilloscope to H1 and adjust RV204 for 0 V dc VTVM reading or the waveform on oscilloscope as shown below.
 3. Connect VTVM or oscilloscope to H2 and adjust RV205 for 0 V dc VTVM reading or the waveform on oscilloscope as shown below.
- Note:** Set the sweep time to longer for easy checking the waveform.

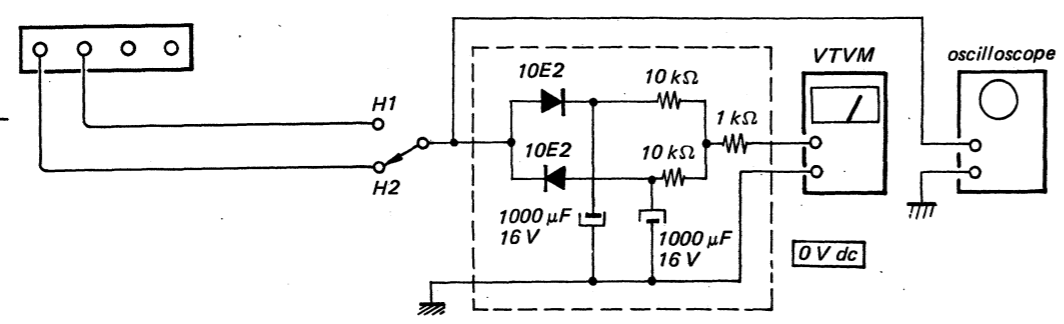
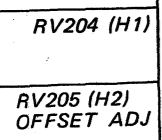
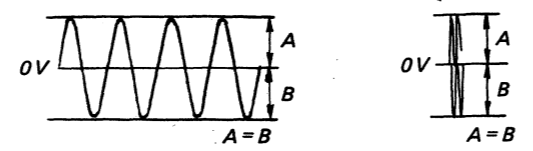

4-1. MOUNTING DIAGRAMS
[Power Supply Board]
— Conductor Side —

Canadian model

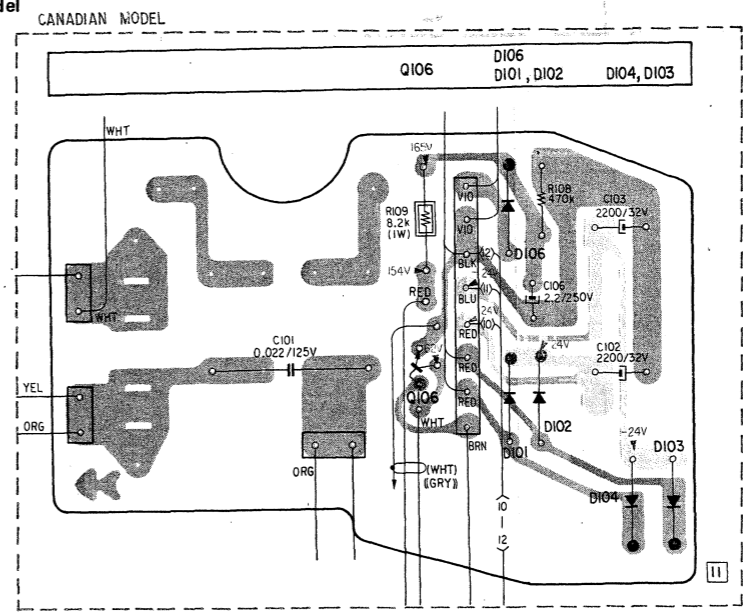

E, AEP, UK model

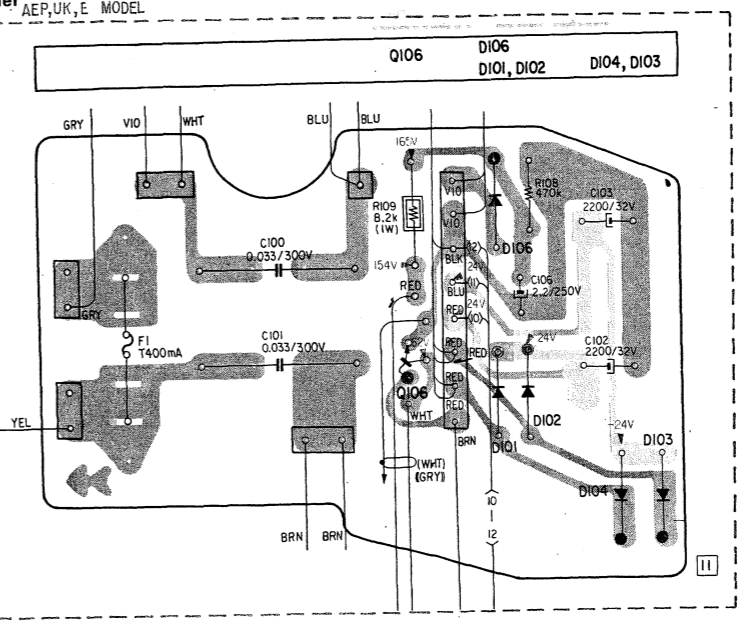

• Color code of sleeving over the end of the jacket.

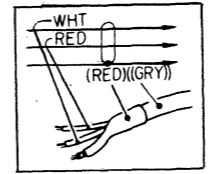

- ○ : parts extracted from the component side.
- ● : parts extracted from the conductor side.
- ▲ : nonflammable resistor.

- Voltages are dc with respect to ground unless otherwise noted.
- Readings are taken at 33 rpm with a VOM (20 kΩ/V).
- () : 45 rpm
- < > : S3 is ON.
- [] : B+ pattern
- [] : B- pattern

PS-X4 PS-X4

4.3. SCHEMATIC DIAGRAM

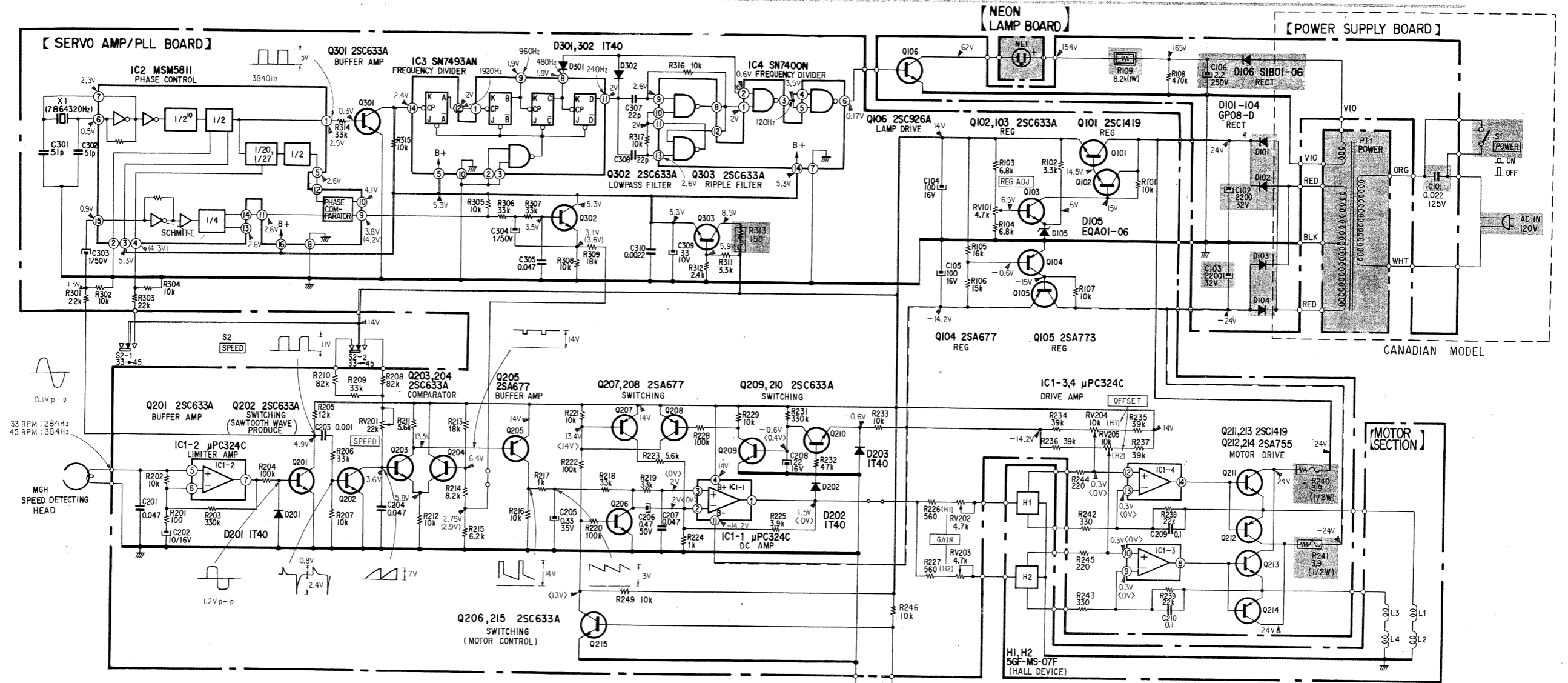

- All capacitors are in μF unless otherwise noted. $\text{pF} = \mu\mu\text{F}$ 50WV or less are not indicated except for electrolytics.
- All resistors are in ohms, $\frac{1}{4}\text{W}$ unless otherwise noted. $\text{k}\Omega = 1000\Omega$, $\text{M}\Omega = 1000\text{k}\Omega$
- : nonflammable resistor.
- : fusible resistor.

- : B+ bus.
- : panel designation.
- : B- bus.
- : adjustment for repair.
- : direct connection to points marked --- on the chassis.

Note: The components identified by shading are critical for safety. Replace only with part number specified.

- Voltages are dc with respect to ground unless otherwise noted.
- Readings are taken at 33 rpm with a VOM (20 $\text{k}\Omega/\text{V}$).
() : 45 rpm
< > : S3 is ON.
- Voltage variations may be noted due to normal production tolerances.
- Switch

Ref. No.	Switch	Position
S1	POWER	OFF
S2	SPEED	33
S3	MOTOR	OFF

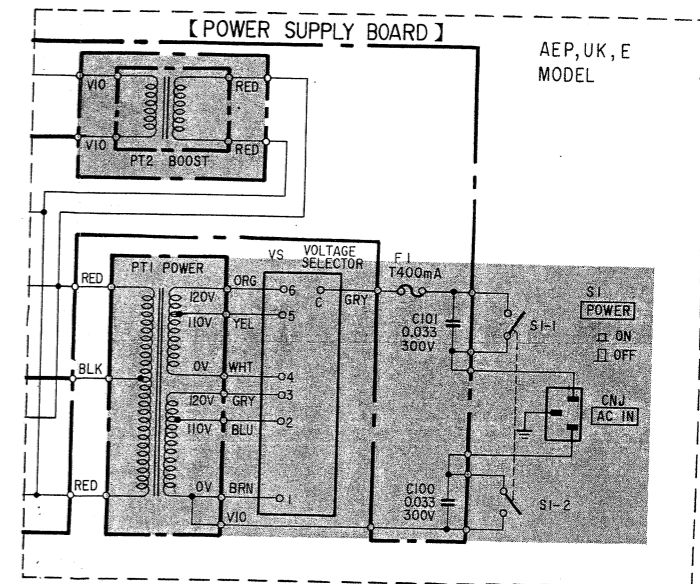

5-3.

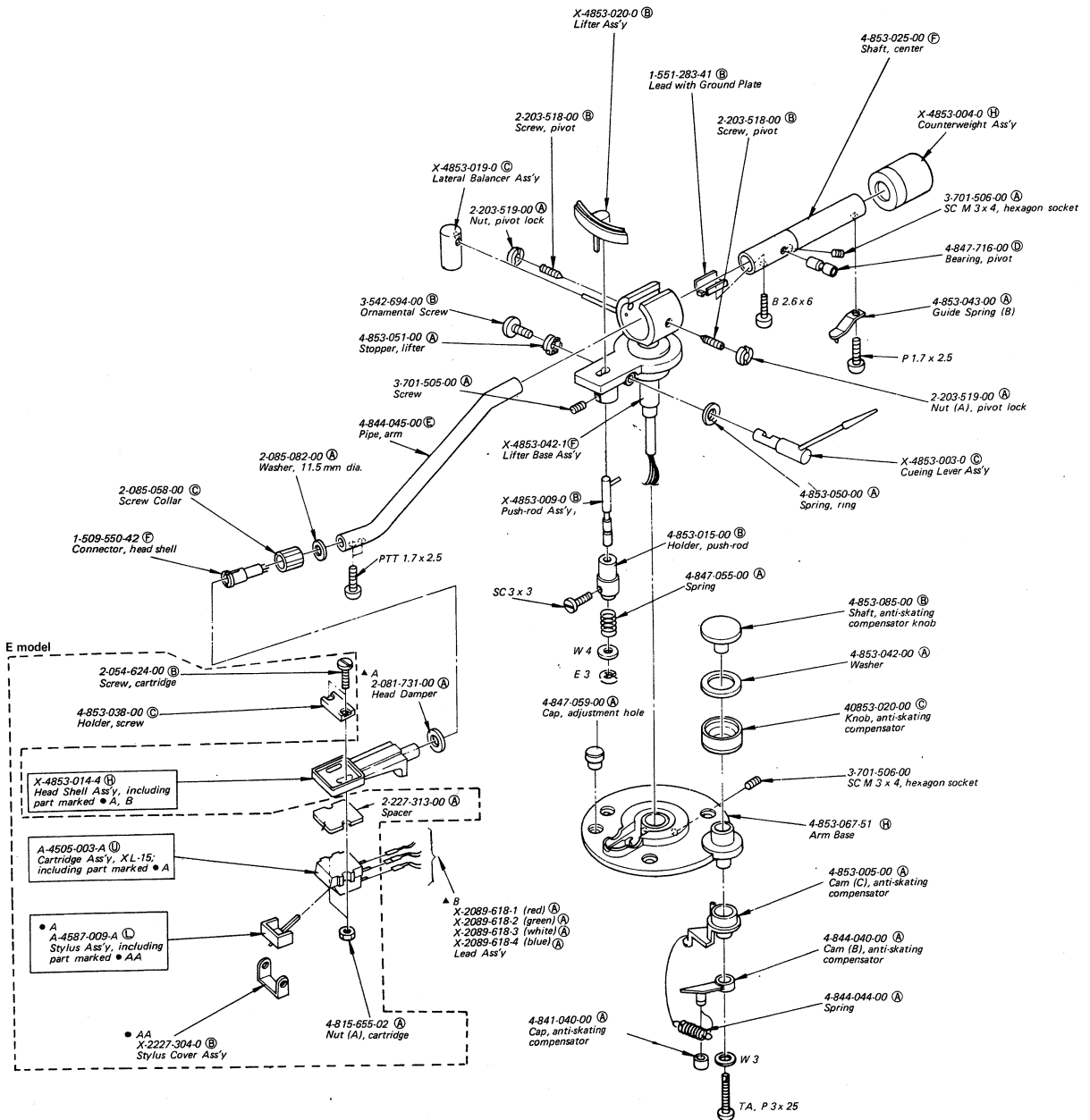

Note:

- Items with no part number and/or no description are not stocked because they are seldom required for routine service.
- All screws are Phillips (cross recess) type unless otherwise noted.
(-) = slotted head
- Circled letters (A to Z) are applicable to European models only.

SECTION 6
ELECTRICAL PARTS LIST

Note: Circled letters (**A** to **Z**) are applicable to European models only.

Ref. No. Part No. Description

SEMICONDUCTORS

Transistors

⇒ Q101	(D) 2SC1061
⇒ Q102, 103	(B) 2SC634A
⇒ Q104	(C) 2SA678
⇒ Q105	(C) 2SA684
Q106	(C) 2SC926A
⇒ Q201 - 204	(B) 2SC634A
⇒ Q205	(C) 2SA678
⇒ Q206	(B) 2SC634A
⇒ Q207, 208	(C) 2SA678
⇒ Q209, 210	(B) 2SC634A
⇒ Q211	(D) 2SC1061
⇒ Q212	(E) 2SA671
⇒ Q213	(D) 2SC1061
⇒ Q214	(E) 2SA671
⇒ Q215	(B) 2SC634A
⇒ Q301, 302	(B) 2SC634A

Diodes

⇒ D101 - 104	(B) 10E2
⇒ D105	(B) EQB01-06
⇒ D106	(B) SIB01-06
⇒ D201 - 203	(B) 1S1555
⇒ D301, 302	(B) 1S1555

ICs

IC1	(G) μ PC324C
IC2	(L) MSM5811

Ref. No. Part No. Description

IC3	(K) M53293P
IC4	(E) M53200P
H1, 2	(D) 5G1-MS-071

Transformers

PT1	1-442-877-00	(L) Power (Canadian Model)
PT1	1-442-878-00	(M) Power (AEP, UK, E Model)
PT2	1-442-879-00	(T) Boost (AEP, UK, E Model)

CAPACITORS

All capacitors are in μ F and ceramic unless otherwise noted.
50WV or less are not indicated except for electrolytics.
pF = μ μ F, elect = electrolytic

C100, 101	1-108-750-62	(B) 0.033	300 V	mylar
				(AEP, UK, E Model)
C101	1-130-098-11	(C) 0.022	125 V	polystyrol
				(Canadian Model)
C102, 103	1-123-047-11	(C) 2200	32 V	elect
C104, 105	1-123-193-11	(B) 100	16 V	elect
C106	1-123-027-11	(B) 2.2	250 V	elect

C201	1-101-925-11	(A) 0.047		
C202	1-121-651-11	(A) 10	16 V	elect
C203	1-102-074-11	(A) 0.001		
C204	1-108-595-12	(B) 0.047		mylar
C205	1-131-212-11	(B) 0.33	35 V	tantalum
C206	1-121-951-11	(K) 0.47	50 V	elect
C207	1-101-925-11	(A) 0.047		
C208	1-123-191-11	(A) 22	16 V	elect
C209, 210	1-108-251-12	(B) 0.1		mylar
C301, 302	1-102-491-11	(A) 51 p		
C303	1-121-391-11	(A) 1	50 V	elect
C304	1-121-952-11	(A) 1	50 V	elect
C305	1-101-925-11	(A) 0.047		
C307, 308	1-102-967-11	(A) 22 p		
C309	1-123-194-11	(A) 33	10 V	elect
C310	1-101-919-11	(A) 0.0022		

⇒: Due to standardization, interchangeable replacements may be substituted for parts specified in the diagrams.

Note: The components identified by shading are critical for safety. Replace only with part number specified.

Note: Circled letters (A) to (Z) are applicable to European models only.

Ref. No. Part No. Description

RESISTORS

All resistors are in ohms. Common 1/4W carbon resistors are omitted. Check schematic diagram for values.

R109 1-213-154-11 (A) 8.2k 1W metal oxide

R240, 241 1-217-429-11 (B) 3.9 1/2W wirewound

R313 1-217-401-11 (B) 150 1/4W fusible

RV101 1-224-644-XX (B) 4.7k, adjustable

RV201 1-224-646-XX (B) 22k, adjustable

RV202, 203 1-224-644-XX (B) 4.7k, adjustable

RV204, 205 1-224-634-11 (B) 10k, adjustable

SWITCHES

S1 1-552-018-00 (C) Push, POWER (Canadian Model)

S1 1-552-206-00 (D) Push, POWER (AEP, UK, E Model)

S2 1-516-288-00 (B) Slide, SPEED

S3 1-516-590-11 (C) Reed

MISCELLANEOUS

CNJ 1-509-547-00 (C) Socket, 3-p, AC Input
(AEP, UK, E Model)

F1 1-532-066-00 (B) Fuse 0.4A (AEP, UK, E Model)

MGH 1-543-066-00 (F) Head, speed detector

NE 1-519-152-11 (B) Neon Lamp 10mA

VS 1-508-897-00 (C) Plug, voltage selector
(AEP, UK, E Model)

X1 1-527-304-00 (F) Crystal 7.864320MHz

A-4608-026-A (O) Motor Ass'y

X-2089-618-1 (A) Lead Wire Ass'y (red)-

X-2089-618-2 (A) Lead Wire Ass'y (green)

X-2089-618-3 (A) Lead Wire Ass'y (white)

X-2089-618-4 (A) Lead Wire Ass'y (blue)

1-452-134-00 (A) Magnet

1-509-550-42 (F) Connector, head shell

1-534-538-11 (D) Cord, power (Canadian Model)

1-535-114-00 (A) Terminal with base, 1 p

1-535-115-00 (A) Terminal with base, 2 p

Ref. No. Part No. Description

1-535-116-00 (A) Terminal with base, 3 p

1-535-117-00 (A) Terminal with base, 4 p

1-535-121-00 (A) Terminal with base, 8 p

1-551-063-00 (F) Cord, phono; low capacitance

1-551-283-41 (B) Lead wire with ground plate

ACCESSORIES & PACKING MATERIALS

Part No. Description

X-4853-006-0 (E) Screw Ass'y, cartridge
(AEP, UK, Canadian Model)

including

2-011-002-00 (A) Bag, plastic (AEP, UK, Canadian Model)

2-054-625-00 (A) Screw (C) (AEP, UK, Canadian Model)

2-056-532-00 (B) Screw (A)

2-224-081-00 (A) Screw (E)

2-227-313-00 (A) Spacer

4-815-655-00 (A) Nut (A), cartridge

4-853-038-00 (C) Holder, screw

X-4853-018-0 (C) Sub-weight Ass'y

1-534-754-14 (E) Cord, power (E Model w/parallel blade plug)

1-534-819-00 (G) Cord, power (UK Model)

1-551-216-00 (H) Cord, power (E Model w/euro plug)

3-701-613-00 (A) Bag, plastic

3-701-630-00 (A) Bag, plastic

3-701-806-02 (A) Adaptor, 45 rpm

3-770-345-11 (E) Manual, instruction

3-793-395-14 (B) Gauge, tracking error check

3-793-815-11 (A) Leaflet (power supply caution)

3-849-790-00 (B) Bag, protection

4-844-060-00 (C) Bag, protection

4-848-005-00 (C) Box, accessory

4-848-006-00 (B) Bag, accessory

4-848-012-00 (A) Plate, protection

4-853-836-00 (C) Cushion









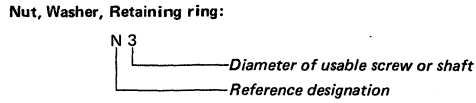
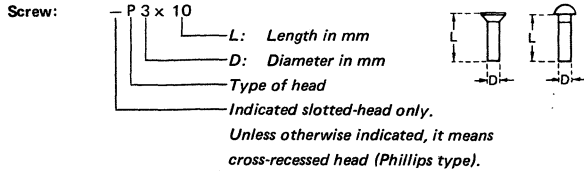



4-853-839-00 (C) Frame













4-853-845-00 (F) Carton

Note: The components identified by shading are critical for safety. Replace only with part number specified.

HARDWARE NOMENCLATURE



Reference Designation	Shape	Description	Remarks
* SCREWS			
P		pan-head screw	binding-head (B) screw for replacement
PWH		pan-head screw with washer face	binding-head (B) screw and flat washer for replacement
PS PSP		pan-head screw with spring washer	binding-head (B) screw and spring washer for replacement
PSW PSPW		pan-head screw with spring and flat washers	binding-head (B) screw and spring and flat washers for replacement
R		round-head screw	binding-head (B) screw for replacement
K		flat-countersunk-head screw	
RK		oval-countersunk-head screw	
B		binding-head screw	
T		truss-head screw	binding-head (B) screw for replacement
F		flat-fillister-head screw	
RF		fillister-head screw	
BV		braizer-head screw	

Reference Designation	Shape	Description	Remarks
SELF-TAPPING SCREWS			
TA		self-tapping screw	ex: TA, P 3 x 10
PTP		pan-head self-tapping screw	binding-head self-tapping (TA, B) screw for replacement
PTPWH		pan-head self-tapping screw with washer face	binding-head self-tapping (TA, B) screw and flat washer for replacement
PTTWH		pan-head thread-rolling screw with washer face	binding-head (B) screw and flat washer for replacement
SET SCREWS			
SC		set screw	
SC		hexagon-socket set screw	ex: SC 2.6 x 4, hexagon socket
NUT			
N		nut	
WASHERS			
W		flat washer	
SW		spring washer	
LW		internal-tooth lock washer	ex: LW3, internal
LW		external-tooth lock washer	ex: LW3, external
RETAINING RINGS			
E		retaining ring	
G		grip-type retaining ring	

AUTOMATIC STEREO TURNTABLE SYSTEM

PS-X4

SUPPLEMENT

File this supplement with the service manual.

AEP Model
UK Model
E Model

No. 1

October, 1977

1. ELECTRICAL PARTS LIST (See page 28.)

	Former	New
C100, 101	1-108-750-62 Ⓑ 0.033 300 V mylar (AEP, UK, E Model)	1-115-148-11 Ⓒ 0.01 450 V paper (AEP, UK, E Model)

2. MOUNTING DIAGRAM : changed portion — Conductor Side — (See page 18.)

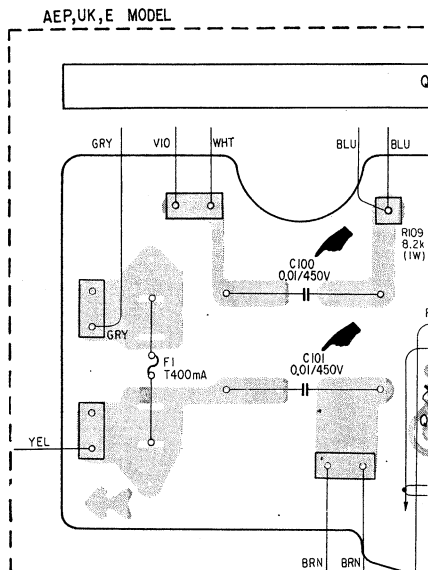

3. SCHEMATIC DIAGRAM (See page 24.) : changed portion

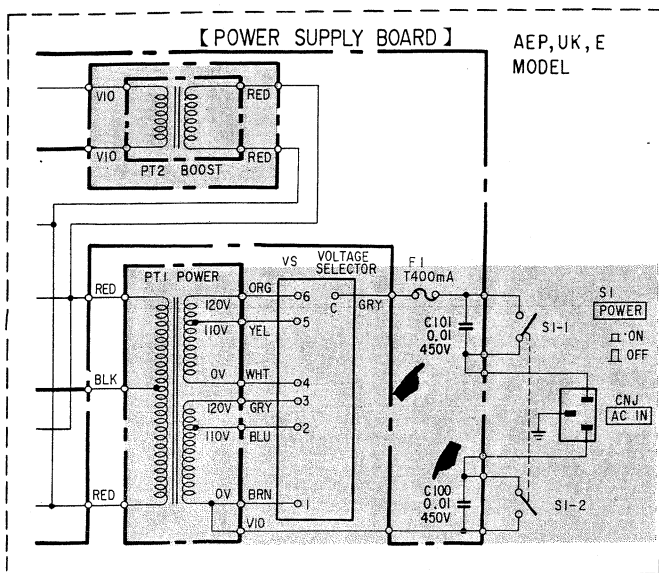

— Component Side — (See page 22.)

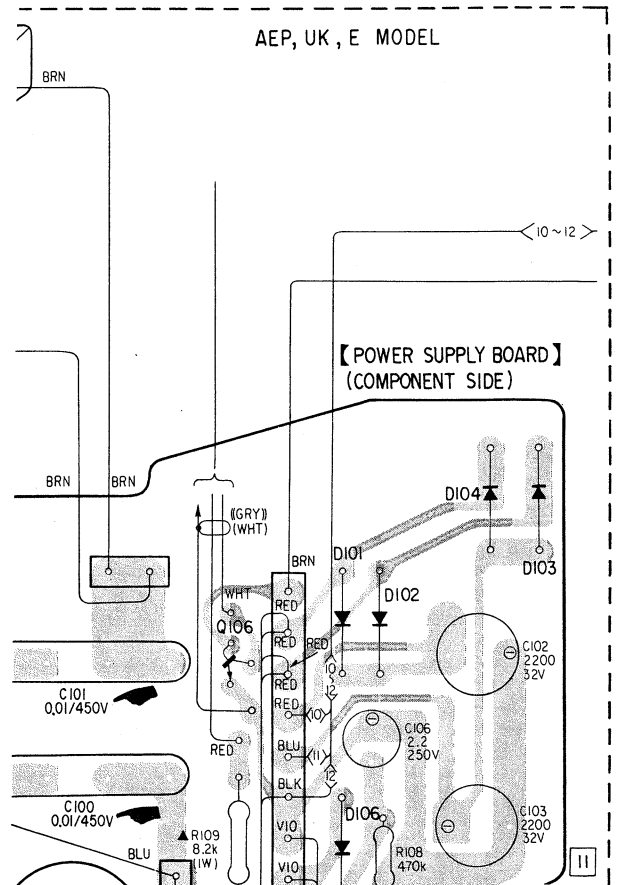

Note: The components identified by shading are critical for safety. Replace only with part number specified.

SONY®

SERVICE MANUAL